



Daikin Altherma high  
temperature split

Technical Data

EPBX10A4V /

EPBX10A9W /

EPBX14A4V /

EPBX14A9W





# TABLE OF CONTENTS

## EPBX10A4V / EPBX10A9W / EPBX14A4V / EPBX14A9W

---

1	<b>Features</b>	4
	EPBX10A4V, EPBX10A9W, EPBX14A4V, EPBX14A9W	4
2	<b>Specifications</b>	5
3	<b>Electrical data</b>	12
4	<b>Combination table</b>	14
5	<b>Dimensional drawings</b>	16
6	<b>Centre of gravity</b>	17
7	<b>Piping diagrams</b>	18
8	<b>Wiring diagrams</b>	19
	Notes & Legend	19
	Wiring Diagrams - Hydro Module	20
	Power Supply, Back-up Heater	24
9	<b>External connection diagrams</b>	25
10	<b>Installation</b>	27
	Installation Method	27
11	<b>Hydraulic performance</b>	28
	Static Pressure Drop Unit	28

# 1 Features

1 - 1 EPBX10A4V, EPBX10A9W, EPBX14A4V, EPBX14A9W

- › New intuitive MMI 5» touchscreen for better user experience
- › Inclusion of all hydraulic components means no third party components are required
- › PCB board and hydraulic components are located in the front for easy access
- › Compact dimensions allows for small installation space, as almost no side clearances are required.
- › The unit's sleek design blends in with other household appliances.
- › Combine with a stainless steel tank or ECH2O thermal store.
- › Integrated back-up heater of 4.5 or 9 kW



-28°

Guaranteed operation down to -28°C



Onecta app (optional)



Online controller

# 2 Specifications

## 2 - 1 Specifications

Technical specifications				EPBX10A4V		
Heater capacity	Step 3		kW	4.5		
Casing	Colour			White + Black		
	Material			Resin, sheet metal		
Dimensions	Unit	Height	mm	840		
		Width	mm	440		
		Depth	mm	390		
	Packed unit	Height	mm	450		
		Width	mm	650		
		Depth	mm	1,016		
Weight	Unit		kg	33		
	Packed unit		kg	38		
Packing	Material			Carton / PP (Straps) / EPS		
	Weight		kg	5		
Pump	Type			Grundfos UPM4L LIN 25-75		
	Nr of speeds			LIN		
	Power input		W	75		
Water side Heat exchanger	Water flow rate	Min.	l/min	22 (1)		
Expansion vessel	Volume		l	7		
	Max. water pressure		bar	3		
	Pre pressure		bar	1		
Water filter	Diameter perforations		mm	0.8		
	Material			Stainless steel / Plastic		
General	Supplier/ Manufacturer details	Name or trademark		Daikin Europe N.V.		
		Name and address		Daikin Europe N.V. - Zandvoordestraat 300, 8400 Oostende, Belgium		
Water circuit	inch		in	G 1" (female)		
	Piping material			Stainless steel		
	inch		in	1"		
	inch		in	1"		
	Safety valve		bar	3		
	Manometer			Digital		
	Drain valve / fill valve			No		
	Shut off valve			Yes		
	flowswitch			No		
	Air purge valve			Yes		
	Pressure	Heating	Max.	bar	3	
	Minimum water volume in the system for cooling			l	25 (2)	
	Minimum water volume in the system for heating			l	55 (2)	
	Sound power level	Nom.		dBA	45 (5)	
Sound pressure level	Nom.		dBA	31 (6)		
Operation range	Heating	Ambient	Min.	°C	0 (3)	
			Max.	°C	0 (3)	
		Water side	Min.	°C	0 (3)	
			Max.	°C	0 (3)	
	Indoor installation	Ambient	Min.	°CDB	5	
		Max.	°CDB	35 (4)		
	Cooling	Ambient	Min.	°CDB	0 (3)	
			Max.	°CDB	0 (3)	
		Water side	Min.	°C	0 (3)	
			Max.	°C	0 (3)	
		Domestic hot water	Water side	Min.	°C	0 (3)
			Max.	°C	0 (3)	
Installation place				Indoor		
Safety devices	Item	01		Thermal cut out		

Electrical specifications				EPBX10A4V	
Power supply	Name			See note 7	
	Phase			1~/3~	
	Frequency		Hz	50	
	Voltage		V	230/400	
	Voltage range	Min.		%	-10
		Max.		%	10
IP class	IP			IP X0B	
Electric heater	Power supply	Name		4V	
		Phase		1~ / 3~	
		Frequency		Hz	50
		Voltage		V	230/400
	Current	Minimum Ssc value			Equipment complying with EN/IEC 61000-3-12
	Recommended fuses		A		0 (8)

## 2 Specifications

### 2 - 1 Specifications

2

Electrical specifications			EPBX10A4V
Wiring connections	Communication cable	Quantity	3+GRD
		Remark	1.5 mm <sup>2</sup>
	Electric meter	Quantity	2
		Remark	Minimum 0.75 mm <sup>2</sup> (16VDC pulse detection) ..
	Preferential kWh rate	Quantity	Power: 2
		Remark	Power 6.3A (Select diameter and type according to national and local regulations)
	Domestic hot water pump	Quantity	3
		Remark	Minimum 0.75 mm <sup>2</sup> (2A inrush, 1A continuous)
	For connection with R6T	Quantity	2
		Remark	Minimum 0.75 mm <sup>2</sup>
	For connection with A3P	Quantity	Depends on thermostat type, cf. installation manual
		Remark	Voltage: 230V / Max. current: 100mA / Min. 0.75mm <sup>2</sup>
	For connection with M2S	Quantity	2
		Remark	Voltage: 230V / Max. current: 100mA / Min. 0.75mm <sup>2</sup>
For connection with optional FWXV* (demand input and output)	Quantity	4	
	Remark	100 mA, minimum 0.75 mm <sup>2</sup>	

(1)Operation area is extended to lower flow rates only in case the unit operates with heat pump only. (Not in startup, no BUH operation, no defrost operation). |

(2)Excluding the water in the unit. This minimum water volume is sufficient for most applications. During critical processes extra water may be required. |

(3)Refer to operation range of the unit. |

(4)Depends on operation mode, refer to installation manual. |

(5)Measured with a pressure drop of 10 kPa in the heating system at an operating condition of leaving water 47-55°C in a room with an ambient of 20°C. DB/WB 7°C/6° |

(6)Value measured in an anechoic room at 1m distance from the unit. It is a relative value, depending on the distance and acoustic environment. The sound pressure level mentioned is measured with a pressure drop of 10 kPa in the heating system at an operatin |

(7)Above mentioned power supply of the hydrobox is for the backup heater only. The switch box and the pump of the hydrobox are supplied via the outdoor unit. The optional domestic hot water tank has a separate power supply. |

(8)Refer to wiring diagram and installation manual for correct recommended fuse depending on power supply and grid connection

Technical specifications				EPBX10A9W
Heater capacity	Step 3		kW	9
Casing	Colour			White + Black
	Material			Resin, sheet metal
Dimensions	Unit	Height	mm	840
		Width	mm	440
		Depth	mm	390
	Packed unit	Height	mm	450
		Width	mm	650
		Depth	mm	1,016
Weight	Unit		kg	33
	Packed unit		kg	38
Packing	Material			Carton / PP (Straps) / EPS
	Weight		kg	5
Pump	Type			Grundfos UPM4L LIN 25-75
	Nr of speeds			LIN
	Power input		W	75
Water side Heat exchanger	Water flow rate	Min.	l/min	22 (1)
Expansion vessel	Volume		l	7
	Max. water pressure		bar	3
	Pre pressure		bar	1
Water filter	Diameter perforations		mm	0.8
	Material			Stainless steel / Plastic
General	Supplier/ Manufacturer details	Name or trademark		Daikin Europe N.V.
		Name and address		Daikin Europe N.V. - Zandvoordestraat 300, 8400 Oostende, Belgium

# 2 Specifications

## 2 - 1 Specifications

Technical specifications				EPBX10A9W		
Water circuit	inch		in	G 1" (female)		
	Piping material			Stainless steel		
	inch		in	1"		
	inch		in	1"		
	Safety valve		bar	3		
	Manometer			Digital		
	Drain valve / fill valve			No		
	Shut off valve			Yes		
	flowswitch			No		
	Air purge valve			Yes		
	Pressure	Heating	Max.	bar	3	
	Minimum water volume in the system for cooling			l	25 (2)	
	Minimum water volume in the system for heating			l	55 (2)	
Sound power level	Nom.		dBA	45 (5)		
Sound pressure level	Nom.		dBA	31 (6)		
Operation range	Heating	Ambient	Min.	°C	0 (3)	
			Max.	°C	0 (3)	
		Water side	Min.	°C	0 (3)	
			Max.	°C	0 (3)	
	Indoor installation	Ambient	Min.	°CDB	5	
			Max.	°CDB	35 (4)	
	Cooling	Ambient	Min.	°CDB	0 (3)	
			Max.	°CDB	0 (3)	
		Water side	Min.	°C	0 (3)	
			Max.	°C	0 (3)	
		Domestic hot water	Water side	Min.	°C	0 (3)
				Max.	°C	0 (3)
Installation place				Indoor		
Safety devices	Item	01		Thermal cut out		

Electrical specifications				EPBX10A9W	
Power supply	Name			See note 7	
	Phase			1~/3~	
	Frequency		Hz	50	
	Voltage		V	230/400	
	Voltage range	Min.		%	-10
		Max.		%	10
IP class	IP			IP X0B	
Electric heater	Power supply	Name		9W	
		Phase		1~/3~	
		Frequency		Hz	50
		Voltage		V	230/400
	Current	Minimum Ssc value			Equipment complying with EN/IEC 61000-3-12
	Recommended fuses		A		0 (8)
Wiring connections	Communication cable	Quantity		3+GRD	
		Remark		1.5 mm <sup>2</sup>	
	Electric meter	Quantity			2
		Remark			Minimum 0.75 mm <sup>2</sup> (16VDC pulse detection) ..
	Preferential kWh rate power supply	Quantity			Power: 2
		Remark			Power 6.3A (Select diameter and type according to national and local regulations)
	Domestic hot water pump	Quantity			3
		Remark			Minimum 0.75 mm <sup>2</sup> (2A inrush, 1A continuous)
	For connection with R6T	Quantity			2
		Remark			Minimum 0.75 mm <sup>2</sup>
	For connection with A3P	Quantity			Depends on thermostat type, cf. installation manual
		Remark			Voltage: 230V / Max. current: 100mA / Min. 0.75mm <sup>2</sup>
For connection with M2S	Quantity			2	
	Remark			Voltage: 230V / Max. current: 100mA / Min. 0.75mm <sup>2</sup>	
For connection with optional FWXV* (demand input and output)	Quantity			4	
	Remark			100 mA, minimum 0.75 mm <sup>2</sup>	

(1)Operation area is extended to lower flow rates only in case the unit operates with heat pump only. (Not in startup, no BUH operation, no defrost operation). |

(2)Excluding the water in the unit. This minimum water volume is sufficient for most applications. During critical processes extra water may be required. |

# 2 Specifications

## 2 - 1 Specifications

(3)Refer to operation range of the unit. |

(4)Depends on operation mode, refer to installation manual. |

(5)Measured with a pressure drop of 10 kPa in the heating system at an operating condition of leaving water 47-55°C in a room with an ambient of 20°C. DB/WB 7°C/6°. |

(6)Value measured in an anechoic room at 1m distance from the unit. It is a relative value, depending on the distance and acoustic environment. The sound pressure level mentioned is measured with a pressure drop of 10 kPa in the heating system at an operatin |

(7)Above mentioned power supply of the hydrobox is for the backup heater only. The switch box and the pump of the hydrobox are supplied via the outdoor unit. The optional domestic hot water tank has a separate power supply. |

(8)Refer to wiring diagram and installation manual for correct recommended fuse depending on power supply and grid connection

2

Technical specifications				EPBX14A4V	
Heater capacity	Step 3		kW	4.5	
Casing	Colour			White + Black	
	Material			Resin, sheet metal	
Dimensions	Unit	Height	mm	840	
		Width	mm	440	
		Depth	mm	390	
	Packed unit	Height	mm	450	
		Width	mm	650	
		Depth	mm	1,016	
Weight	Unit		kg	34	
	Packed unit		kg	39	
Packing	Material			Carton / PP (Straps) / EPS	
	Weight		kg	5	
Pump	Type			Grundfos UPM10XL LIN 25-125	
	Nr of speeds			LIN	
	Power input		W	180	
Water side Heat exchanger	Water flow rate	Min.	l/min	24 (1)	
Expansion vessel	Volume		l	7	
	Max. water pressure		bar	3	
	Pre pressure		bar	1	
Water filter	Diameter perforations		mm	0.8	
	Material			Stainless steel / Plastic	
General	Supplier/ Manufacturer details	Name or trademark Name and address		Daikin Europe N.V. Daikin Europe N.V. - Zandvoordestraat 300, 8400 Oostende, Belgium	
	Water circuit	inch	in	G 1" (female)	
	Piping material			Stainless steel	
	inch		in	1"	
	inch		in	1"	
	Safety valve		bar	3	
	Manometer			Digital	
	Drain valve / fill valve			No	
	Shut off valve			Yes	
	flowswitch			No	
	Air purge valve			Yes	
	Pressure	Heating	Max. bar	3	
	Minimum water volume in the system for cooling		l	30 (2)	
	Minimum water volume in the system for heating		l	65 (2)	
Sound power level	Nom.		dB(A)	45 (5)	
Sound pressure level	Nom.		dB(A)	31 (6)	
Operation range	Heating	Ambient	Min.	°C	0 (3)
			Max.	°C	0 (3)
		Water side	Min.	°C	0 (3)
			Max.	°C	0 (3)
	Indoor installation	Ambient	Min.	°CDB	5
			Max.	°CDB	35 (4)
		Cooling	Min.	°CDB	0 (3)
			Max.	°CDB	0 (3)
	Domestic hot water	Water side	Min.	°C	0 (3)
			Max.	°C	0 (3)
		Water side	Min.	°C	0 (3)
			Max.	°C	0 (3)
	Installation place				Indoor
	Safety devices	Item	01		Thermal cut out

Electrical specifications				EPBX14A4V	
Power supply	Name			See note 7	
	Phase			1~/3~	
	Frequency		Hz	50	
	Voltage		V	230/400	
	Voltage range	Min.		%	-10
		Max.		%	10
	IP class	IP			IP X0B

## 2 Specifications

### 2 - 1 Specifications

Electrical specifications				EPBX14A4V	
Electric heater	Power supply	Name		4V	
		Phase		1~ / 3~	
		Frequency	Hz	50	
		Voltage	V	230/400	
	Current	Minimum Ssc value		Equipment complying with EN/IEC 61000-3-12	
	Recommended fuses	A		0 (8)	
Wiring connections	Communication cable	Quantity		3+GRD	
		Remark		1.5 mm <sup>2</sup>	
	Electric meter	Quantity			2
		Remark			Minimum 0.75 mm <sup>2</sup> (16VDC pulse detection) ..
	Preferential kWh rate power supply	Quantity			Power: 2
		Remark			Power 6.3A (Select diameter and type according to national and local regulations)
	Domestic hot water pump	Quantity			3
		Remark			Minimum 0.75 mm <sup>2</sup> (2A inrush, 1A continuous)
	For connection with R6T	Quantity			2
		Remark			Minimum 0.75 mm <sup>2</sup>
	For connection with A3P	Quantity			Depends on thermostat type, cf. installation manual
		Remark			Voltage: 230V / Max. current: 100mA / Min. 0.75mm <sup>2</sup>
	For connection with M2S	Quantity			2
Remark				Voltage: 230V / Max. current: 100mA / Min. 0.75mm <sup>2</sup>	
For connection with optional FWXV* (demand input and output)	Quantity			4	
	Remark			100 mA, minimum 0.75 mm <sup>2</sup>	

(1)Operation area is extended to lower flow rates only in case the unit operates with heat pump only. (Not in startup, no BUH operation, no defrost operation). |

(2)Excluding the water in the unit. This minimum water volume is sufficient for most applications. During critical processes extra water may be required. |

(3)Refer to operation range of the unit. |

(4)Depends on operation mode, refer to installation manual. |

(5)Measured with a pressure drop of 10 kPa in the heating system at an operating condition of leaving water 47-55°C in a room with an ambient of 20°C. DB/WB 7°C/6°. |

(6)Value measured in an anechoic room at 1m distance from the unit. It is a relative value, depending on the distance and acoustic environment. The sound pressure level mentioned is measured with a pressure drop of 10 kPa in the heating system at an operatin |

(7)Above mentioned power supply of the hydrobox is for the backup heater only. The switch box and the pump of the hydrobox are supplied via the outdoor unit. The optional domestic hot water tank has a separate power supply. |

(8)Refer to wiring diagram and installation manual for correct recommended fuse depending on power supply and grid connection

Technical specifications				EPBX14A9W
Heater capacity	Step 3		kW	9
Casing	Colour			White + Black
	Material			Resin, sheet metal
Dimensions	Unit	Height	mm	840
		Width	mm	440
		Depth	mm	390
	Packed unit	Height	mm	450
		Width	mm	650
	Depth	mm	1,016	
Weight	Unit		kg	34
	Packed unit		kg	39
Packing	Material			Carton / PP (Straps) / EPS
	Weight		kg	5
Pump	Type			Grundfos UPM10XL LIN 25-125
	Nr of speeds			LIN
	Power input		W	180
Water side Heat exchanger	Water flow rate	Min.	l/min	24 (1)
Expansion vessel	Volume		l	7
	Max. water pressure		bar	3
	Pre pressure		bar	1
Water filter	Diameter perforations		mm	0.8
	Material			Stainless steel / Plastic
General	Supplier/ Manufacturer details	Name or trademark		Daikin Europe N.V.
		Name and address		Daikin Europe N.V. - Zandvoordestraat 300, 8400 Oostende, Belgium

## 2 Specifications

### 2 - 1 Specifications

**2**

Technical specifications				EPBX14A9W		
Water circuit	inch		in	G 1" (female)		
	Piping material			Stainless steel		
	inch		in	1"		
	inch		in	1"		
	Safety valve		bar	3		
	Manometer			Digital		
	Drain valve / fill valve			No		
	Shut off valve			Yes		
	flowswitch			No		
	Air purge valve			Yes		
	Pressure	Heating	Max.	bar	3	
	Minimum water volume in the system for cooling			l	30 (2)	
	Minimum water volume in the system for heating			l	65 (2)	
	Sound power level	Nom.		dBA	45 (5)	
Sound pressure level	Nom.		dBA	31 (6)		
Operation range	Heating	Ambient	Min.	°C	0 (3)	
			Max.	°C	0 (3)	
		Water side	Min.	°C	0 (3)	
			Max.	°C	0 (3)	
	Indoor installation	Ambient	Min.	°CDB	5	
			Max.	°CDB	35 (4)	
	Cooling	Ambient	Min.	°CDB	0 (3)	
			Max.	°CDB	0 (3)	
		Water side	Min.	°C	0 (3)	
			Max.	°C	0 (3)	
		Domestic hot water	Water side	Min.	°C	0 (3)
				Max.	°C	0 (3)
Installation place				Indoor		
Safety devices	Item	01		Thermal cut out		

Electrical specifications				EPBX14A9W	
Power supply	Name			See note 7	
	Phase			1~/3~	
	Frequency		Hz	50	
	Voltage		V	230/400	
	Voltage range	Min.		%	-10
		Max.		%	10
IP class	IP			IP X0B	
Electric heater	Power supply	Name		9W	
		Phase		1~/3~	
		Frequency		Hz	50
		Voltage		V	230/400
	Current	Minimum Ssc value			Equipment complying with EN/IEC 61000-3-12
	Recommended fuses		A		0 (8)
Wiring connections	Communication cable	Quantity		3+GRD	
		Remark		1.5 mm <sup>2</sup>	
	Electric meter	Quantity			2
		Remark			Minimum 0.75 mm <sup>2</sup> (16VDC pulse detection) ..
	Preferential kWh rate power supply	Quantity			Power: 2
		Remark			Power 6.3A (Select diameter and type according to national and local regulations)
	Domestic hot water pump	Quantity			3
		Remark			Minimum 0.75 mm <sup>2</sup> (2A inrush, 1A continuous)
	For connection with R6T	Quantity			2
		Remark			Minimum 0.75 mm <sup>2</sup>
	For connection with A3P	Quantity			Depends on thermostat type, cf. installation manual
		Remark			Voltage: 230V / Max. current: 100mA / Min. 0.75mm <sup>2</sup>
For connection with M2S	Quantity			2	
	Remark			Voltage: 230V / Max. current: 100mA / Min. 0.75mm <sup>2</sup>	
For connection with optional FWXV* (demand input and output)	Quantity			4	
	Remark			100 mA, minimum 0.75 mm <sup>2</sup>	

(1)Operation area is extended to lower flow rates only in case the unit operates with heat pump only. (Not in startup, no BUH operation, no defrost operation). |

(2)Excluding the water in the unit. This minimum water volume is sufficient for most applications. During critical processes extra water may be required. |

## 2 Specifications

### 2 - 1 Specifications

(3)Refer to operation range of the unit. |

(4)Depends on operation mode, refer to installation manual. |

(5)Measured with a pressure drop of 10 kPa in the heating system at an operating condition of leaving water 47-55°C in a room with an ambient of 20°C. DB/WB 7°C/6°. |

(6)Value measured in an anechoic room at 1m distance from the unit. It is a relative value, depending on the distance and acoustic environment. The sound pressure level mentioned is measured with a pressure drop of 10 kPa in the heating system at an operatin |

(7)Above mentioned power supply of the hydrobox is for the backup heater only. The switch box and the pump of the hydrobox are supplied via the outdoor unit. The optional domestic hot water tank has a separate power supply. |

(8)Refer to wiring diagram and installation manual for correct recommended fuse depending on power supply and grid connection

# 3 Electrical data

## 3 - 1 Electrical Data

3

EPBX10A4V  
 EPBX10A9W  
 EPBX14A4V  
 EPBX14A9W

Electrical specifications of the backup heaters and booster heaters

Type		9W			4V				
Capacity setting	[kW]	1 - 9	1 - 6		1 - 4.5				
Capacity stage · ·		9	6		9				
Capacity stage ·1·	kW	1	1		0.5				
Capacity stage ·2·	kW	2	2		1				
Capacity stage ·3·	kW	3	3		1.5				
Capacity stage ·4·	kW	4	4		2				
Capacity stage ·5·	kW	5	5		2.5				
Capacity stage ·6·	kW	6	6		3				
Capacity stage ·7·	kW	7	-		3.5				
Capacity stage ·8·	kW	8	-		4				
Capacity stage ·9·	kW	9	-		4.5				
<b>Backup heater</b>	Minimum time delay between stages	Max net change ≤ ·1· kW		10s					
		Max net change ≤ ·2· kW		40s					
		Max net change > ·2· kW		150s					
	Power supply (1)	Voltage	390 - 410V	220 - 240V		390 - 410V	220 - 240 V		
	Capacity	9kW	6kW		4.5kW				
	Rated current	13A	13A	26.1A <sup>(2)</sup>	6.5A	13A	19.6A <sup>(2)</sup>	17A <sup>(2)</sup>	19.6A <sup>(2)</sup>
	Phase	3N~	1N~		3N~	1N~		3~	2~
	Frequency	50Hz							
	Type of wires	Must comply with national wiring regulation							
		Min. ·2.5· mm <sup>2</sup>	Min. ·6· mm <sup>2</sup>	Min. ·2.5· mm <sup>2</sup>		Min. ·4· mm <sup>2</sup>	Min. ·2.5· mm <sup>2</sup>	Min. ·4· mm <sup>2</sup>	
		·5·-wire cable	·3·-wire cable	·5·-wire cable		·3·-wire cable	·4·-wire cable	·3·-wire cable	
	Recommended overcurrent protection	3L+N+GND	2L+2N+GND	L+N+GND	3L+N+GND	2L+2N+GND	L+N+GND	3L+GND	2L+GND
	Earth leakage circuit breaker	4-pole ·16· A		2-pole ·32· A	4-pole ·10· A	4-pole ·16· A	2-pole ·25· A	4-pole ·20· A	2-pole ·25· A
		Must comply with national wiring regulation							
<b>Booster heater (optional)(·*KHW *· models)</b>	Capacity setting	[kW]	3						
	Capacity stage · ·		1						
	Minimum time delay between stages		Note ·3·						
	Nominal running current	+EK*V3	A	13					
<b>Notes</b>	(1)	The above-mentioned power supply of the hydrobox is for the backup heater only. The optional domestic hot water tank has a separate power supply.							
	(2)	The equipment complies with EN/IEC 61000-3-12.							
	EN/IEC 61000-3-12	European/International Technical Standard setting the limits for harmonic currents produced by equipment connected to public low-voltage systems with input current > 16 A and ≤ 75 A per phase.							

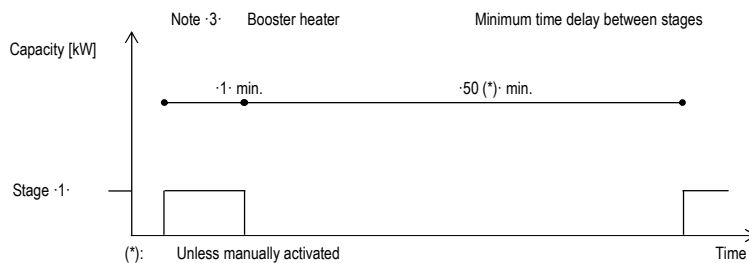

4D154616A

# 3 Electrical data

## 3 - 1 Electrical Data

### EPBX10A4V

#### \* Electrical meter specification

### EPBX10A9W

- Pulse meter type/voltage-free contact for 5 V DC detection by PCB.

### EPBX14A4V

- Possible number of pulses

·0.1- pulse/kWh

·1- pulse/kWh

·10- pulse/kWh

·100- pulse/kWh

·1000- pulse/kWh

### EPBX14A9W

- Pulse duration

minimum On time: ·40ms-

Minimum OFF time: ·100ms-

- Measurement type (depending on installation)

Single-phase AC meter

Three-phase AC meter

Balanced loads

Three-phase AC meter

Unbalanced loads

#### \* Electrical meter installation guideline

- It is the responsibility of the installer to cover the complete power consumption with electrical meters (combination of estimation and metering is not allowed).

- Required number of electrical meters

Outdoor unit type	EPSK(06/08/10)A*V3								EPSK(08/10)A*W1				EPSK(12/14)A*W1											
Indoor unit type	EPBX10A*																							
Backup heater type	4V				9W				4V				9W				4V				9W			
Backup heater power supply	1~ 230V	3~ 400V	3~ 230V	2~ 230V	1~ 230V	3~ 400V	3~ 230V	2~ 230V	1~ 230V	3~ 400V	3~ 230V	2~ 230V	1~ 230V	3~ 400V	3~ 230V	2~ 230V	1~ 230V	3~ 400V	3~ 230V	2~ 230V	1~ 230V	3~ 400V		
Backup heater configuration	Step ·0.5kW·				Step ·1kW·				Step ·0.5kW·				Step ·1kW·				Step ·0.5kW·				Step ·1kW·			
<b>Indoor unit supplied separately or from outdoor unit (normal kWh rate power supply)</b>																								
Electrical meter type	1~	-	-	-	1	-	-	-	-	-	-	-	-	-	-	-	-	-	-	-	-	-		
	3~ balanced	-	-	-	-	-	-	-	-	-	-	-	-	-	-	-	-	-	-	-	-	-		
	3~ unbalanced	-	1	1	1	-	1	1	1	1	1	1	1	1	1	1	1	1	1	1	1	1		
<b>Indoor unit supplied separately (preferential kWh rate power supply)</b>																								
Electrical meter type	1~	2	1	-	2	1	1	-	-	-	-	1	-	1	-	-	-	-	1	-	-	-		
	3~ balanced	-	-	-	-	-	-	-	-	-	-	-	-	-	-	-	-	-	-	-	-	-		
	3~ unbalanced	-	1	2	2	-	1	1	2	2	2	2	1	2	1	2	2	2	1	2	1	2		
<b>Indoor unit supplied from outdoor unit (preferential kWh rate power supply) <sup>(1)</sup></b>																								
Electrical meter type	1~	1	-	-	1	-	-	-	-	-	-	-	-	-	-	-	-	-	-	-	-	-		
	3~ balanced	-	-	-	-	-	-	-	-	-	-	-	-	-	-	-	-	-	-	-	-	-		
	3~ unbalanced	-	1	1	1	-	1	1	1	1	1	1	1	1	1	1	1	1	1	1	1	1		

(1) only if the electricity company demands to consume a limited amount of electricity and does not shut down the power supply

**4D154620**

# 4 Combination table

## 4 - 1 Combination Table

**4**
**EPBX10A4V** Factory-mounted equipment for ·EPBX(10/14)AF(4V/9W)·

**EPBX10A9W**
**EPBX14A4V**
**EPBX14A9W**

Description	EPBX(10/14)AF*	
	4V	9W
Reversible model ·EPBX·		
Backup heater ·4.5KW 1N~230V·	0	-
Backup heater ·4.5KW 3~400V·	0	-
Backup heater ·6-9KW 1N~230V·	-	0
Backup heater ·6-9KW 3N~400V·	-	0

**Kit availability for indoor units**

Reference	Description	EPBX(10/14)AF*	
		4V	9W
EPBX*	Reversible indoor unit		
BRC1HHDA*	HCI (Human Comfort Interface)	0	0
EKPPCAB4	PC cable	*(1)	0
KRCS01-1	Remote indoor sensor	*(2)	0
EKRSCA1	Remote sensor for outdoor	*(2)	0
FWXV10-15-20ABTV3(R)	Heat pump convector	*(3)	0
FWXT10-15-20ABTV3*	Heat pump convector	*(3)	0
FWXM10-15-20AATV3(R)	Heat pump convector	*(3)	0
EKRRTWA	Wired room thermostat	0	0
EKRTRB	Wireless room thermostat	0	0
EKRSETS	External sensor room thermostat	*(4)	0
EKWUFHTA1V3	Multi-zoning base unit 230 V	*(5)	0
EKWCTRD1V3	Digital thermostat 230 V	*(5)	0
EKWCTRAN1V3	Analogue thermostat 230 V	*(5)	0
EKWCVATR1V3	Actuator 230 V	*(5)	0
EKRRTVATR2BA	Radiator Thermostat	*(6)	0
EKRUFHT61V3	Floor Heating Controller	*(6)	0
EKRACPUR1PA	Access Point	*(6)	0
EKRMBEV1V3	Multi IO Box	*(6)	0
EKRIBDI1V3	Basic IO Box	*(6)	0
EKRCTRD12BA	Room Thermostat — ·1·	*(6)	0
EKRCTRD13BA	Room Thermostat — ·2·	*(6)	0
EKRSENDI1BA	Room Sensor	*(6)	0
EKRELSG	Relay for Smart Grid	0	0
AFVALVE125	Freeze protection valve	0	0
ESAE04A*	Daikin Residential Controller	0	0
EKBURW1	BUH Rewiring kit	0	
EKBURW3	BUH Rewiring kit	0	
EKMIKPOAF	Mixing kit – PCB only	*(7)	0
EKMIKPHAF	Mixing kit – PCB with hydraulics	*(7)	0
EKMIKHMAF	Hydraulics – mixed pump group	0	0
EKMIKHUAF	Hydraulics – unmixed pump group	*(8)	0
EKMIKBAF	Balancing vessel	0	0
EKMIKIDAF	Distributor for balancing vessel	0	0

**Outdoor combination table for ·EPBX(10/14)AF\*·**

Description	EPBK06ARV3	EPBK(08/10)AR(V3/W1)	EPBK(12/14)ARW1
EPBX10AF*	0	0	-
EPBX14AF*	-	-	0

**Kit availability for outdoor units**

Reference	Description	EPBK06ARV3	EPBK(08/10)AR(V3/W1)	EPBK(12/14)ARW1
EKMST4	Mounting stand	0	0	0

Reference	Description	EPBX(10/14)AF*	
		4V	9W
EPBX*	Reversible indoor unit		
EKHWS(P)150D3V3	Domestic hot water tank ·150 l 1~230 V·	0	0
EKHWS(P)180D3V3	Domestic hot water tank ·180 l 1~230 V·	0	0
EKHWS(P)200D3V3	Domestic hot water tank ·200 l 1~230 V·	0	0
EKHWS(P)250D3V3	Domestic hot water tank ·250 l 1~230 V·	0	0
EKHWS(P)300D3V3	Domestic hot water tank ·300 l 1~230 V·	0	0
EKHWSU150D3V3	Domestic hot water tank ·150 l 1~230 V·	0	0
EKHWSU180D3V3	Domestic hot water tank ·180 l 1~230 V·	0	0
EKHWSU200D3V3	Domestic hot water tank ·200 l 1~230 V·	0	0
EKHWSU250D3V3	Domestic hot water tank ·250 l 1~230 V·	0	0
EKHWSU300D3V3	Domestic hot water tank ·300 l 1~230 V·	0	0
EKHWP500BA	Domestic hot water tank with solar connection	*(9)(10)	0
EKHWP500PBA	Domestic hot water tank with solar connection	*(9)(10)	0
EKHWP300BA	Domestic hot water tank with solar connection	*(9)(10)	0
EKHWP300PBA	Domestic hot water tank with solar connection	*(9)(10)	0
EKHY3PART	Third-party tank connection kit for thermostat pocket	*(11)	0
EKHY3PART2	Third-party tank connection kit for thermostat contact	*(12)	0

**3D154621**

# 4 Combination table

## 4 - 1 Combination Table

EPBX10A4V

EPBX10A9W

EPBX14A4V Kit availability for domestic hot water tanks

EPBX14A9W

Reference	Description	*KHWP*			
		500BA	500PBA	300BA	300PBA
*KHWP*	Domestic hot water tank with solar connection				
*KSRPS4A	Solar pump station	o	o	o	o
EKEPRHLT3HX	Dedicated connection kit available.			o	o
EKEPRHLT5X	Only for reversible models	o	o		

**Notes**

- (1) Data cable for connection with PC.
- (2) Only 1 remote sensor can be connected: indoor OR outdoor sensor.
- (3) The valve kit is mandatory if a heat pump convector is installed on a reversible model (not mandatory for heating only models).
- (4) -EKRTETS- can only be used in combination with -EKRTTB-
- (5) Multi-zoning wired controls
- (6) Daikin Home Controls (wireless)
- (7) Only possible in combination with -EKMIKPOAF-
- (8) Only possible in combination with -EKMIKBVAF- and -EKMIKPHAF- or -EKMIKHUAF-
- (9) Solar pump station
- (10) Dedicated connection kit available: -EKEP\*.
- (11) -EKHY3PART- can be used if you have a tank in which you can insert a thermistor.
- (12) -EKHY3PART2- can be used if you have a tank in which you cannot insert a thermistor.

**Remark**

Other combinations than mentioned in this combination table are prohibited.

**3D154621**

# 5 Dimensional drawings

## 5 - 1 Dimensional Drawings

5

EPBX10A4V  
 EPBX10A9W  
 EPBX14A4V  
 EPBX14A9W

- ① Holes (Ø8.5) for wall fixation
- ② Water out connection (1" F BSP)
- ③ Water in connection (Quick conn M)
- ④ Backup heater
- ⑤ Pump
- ⑥ User interface
- ⑦ Safety valve Pressure
- ⑧ Air purge
- ⑨ Expansion vessel
- ⑩ Magnetic filter / dirt separator
- ⑪ Flow sensor
- ⑫ Gas sensor
- ⑬ Service door
- ⑭ Switch box terminals
- ⑮ Relay for Smart Grid
- ⑯ Space heating water pressure sensor
- ⑰ Shut-off valve (1"-1 1/4 BSP) (male-female)
- ⑱ Shut-off valve normally closed
- ⑲ Switch box terminals for the domestic hot water tank (option)
- ⑳ Power cord routing hole (bottom)
- ㉑ Backup heater power supply
- ㉒ Options

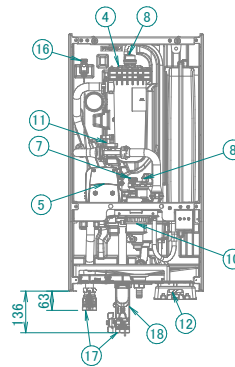
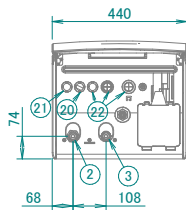
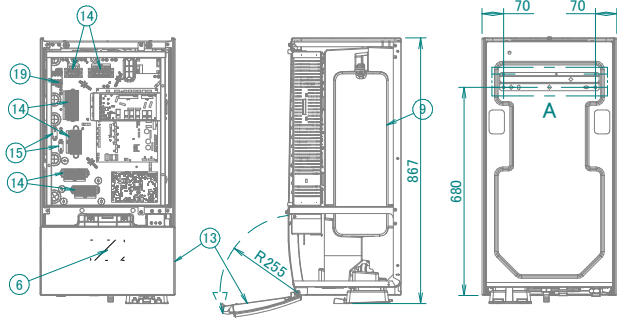
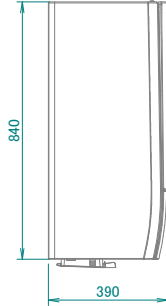
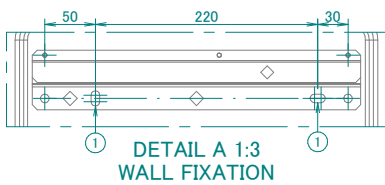

4D154622

# 6 Centre of gravity

6 - 1 Centre of Gravity

EPBX10A4V  
EPBX10A9W  
EPBX14A4V  
EPBX14A9W

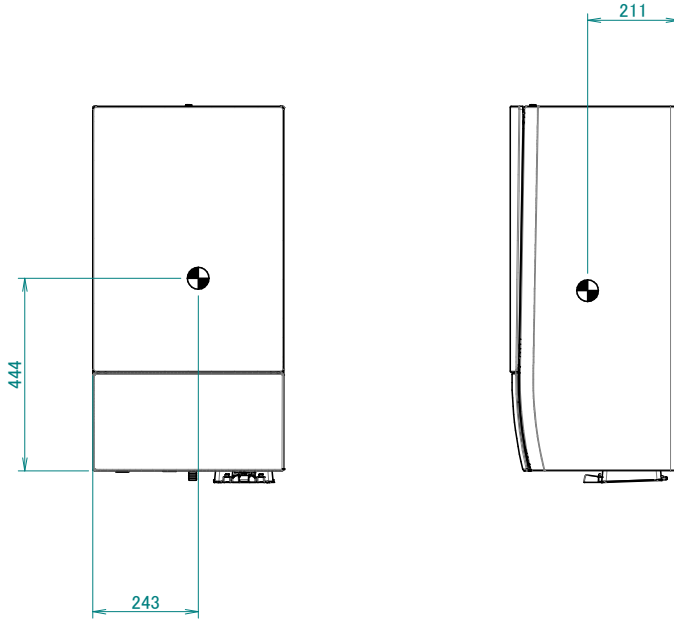

4D154619

# 7 Piping diagrams

## 7 - 1 Piping Diagrams

7

EPBX10A4V  
 EPBX10A9W  
 EPBX14A4V  
 EPBX14A9W

- ① Space heating - water OUT
- ② Water IN connection
- ③ Gas separator
- ④ Magnetic filter / dirt separator
- ⑤ Safety valve
- ⑥ Air purge
- ⑦ Drain valve
- ⑧ Flow sensor
- ⑨ Gas sensor
- ⑩ Expansion vessel
- ⑪ Backup heater
- ⑫ Pump
- ⑬ Space heating water pressure sensor
- ⑭ R1T - Inlet water thermistor
- ⑮ R2T - Outlet water backup heater thermistor
- ⑯ Hose for air purge
- ⑰ Hose for gas
- ⑱ Drain hose for water

Field piping connections

- ① Screw connection · 1" F.
- ② Quick connection
- ③ Shut-off valve · 1"·1 1/4" · (male-female)
- ④ Shut-off valve normally closed ·
- ⑤ Drain outlet · ID18
- ⑥ Screw connection · 1 1/4" F.

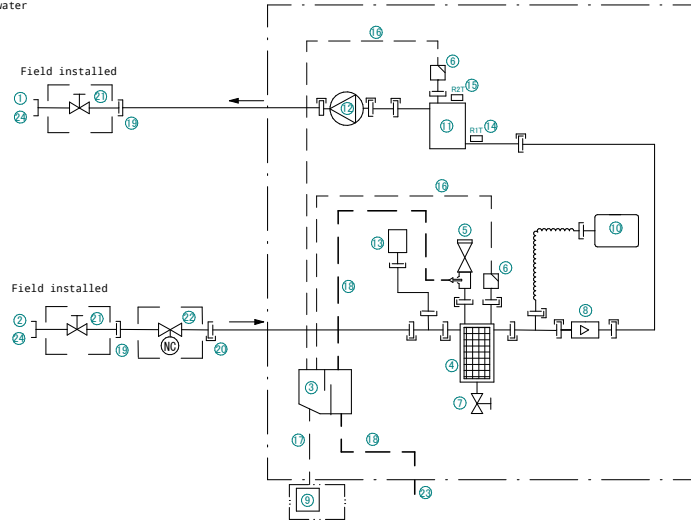

3D151512A

# 8 Wiring diagrams

## 8 - 1 Notes & Legend

### EPBX10A4V / EPBX10A9W EPBX14A4V / EPBX14A9W

#### NOTES to go through before starting the unit

- X2M : Main Terminal Outdoor Unit      X42M, X43M : Field Wiring for High Voltage
- X40M : Main Terminal Indoor Unit      X44M + X45M : Field Wiring for SELV
- X41M : Main Terminal Back-Up Heater      X7M, X8M : BSH Power Supply Terminal

- - - - - : Earth wiring
- . - . - : Field supply
- ① : Several wiring possibilities

- : Option
- : Not mounted in switch box
- : Wiring depending on model
- : PCB

Note 1 : Connection point of the power supply for the BUH should be foreseen outside the unit.

- Backup heater power supply
- 4,5kW (1/N~, 230V)
  - 4,5kW (3/N~, 400V)
  - 4,5kW (3~, 230V)
  - 4,5kW (2~, 230V)
  - 6kW (1/N~, 230V)
  - 9kW (3/N~, 400V)

- User installed options:
- Remote User Interface
  - Ext. indoor thermistor
  - Ext. outdoor thermistor
  - Safety thermostat
  - Smartgrid kit
  - W-LAN Cartridge
  - Bizone Mixing Kit

- Main LWT:
- On/OFF thermostat (wired)
  - On/OFF thermostat (wireless)
  - Ext. thermistor
  - Heat pump convactor

- Add LWT:
- On/OFF thermostat (wired)
  - On/OFF thermostat (wireless)
  - Ext. thermistor
  - Heat pump convactor

#### POSITION IN SWITCH BOX

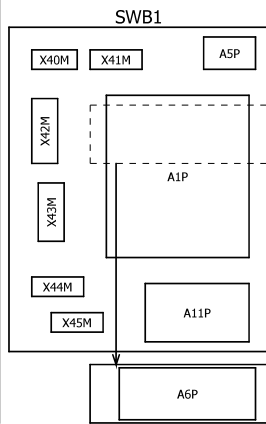

#### LEGEND



Translation can be found in the installation manual.

\* : Optional  
# : Field supply

Part n°	Description
A1P	Hydro PCB
A2P	* On/OFF thermostat (PC=power circuit)
A3P	* Heat Pump Convactor
A5P	Power Supply PCB
A6P	Multi-Step Back-Up Heater PCB
A9P	Daikin Eye (Status indicator)
A11P	Interface PCB
A12P	Display PCB
A14P	* Remote User Interface
A15P	* Receiver PCB (wireless On/OFF thermostat)
A30P	* Bizone Mixing Kit PCB
B2L	Flow sensor
B4L	Gas Sensor
B1PW	Water pressure sensor
CN* (A5P)	Connector
E1H	Backup heater element
E2H	Backup heater element
E3H	Backup heater element
E4H	Backup heater element
E5H	Backup heater element
E6H	* Booster heater element
E*P (A9P)	Indication LED
F1B	# Overcurrent fuse backup heater
F2B	# Overcurrent fuse Main
F3B	# Overcurrent fuse Booster Heater
F1T	Thermal Fuse backup heater
FU1 (A1P)	Fuse T 5 A 250 V for PCB
K1A, K2A	* High voltage smartgrid relay
K3M	* Contactor booster heater
K*R (A*P)	Relay on PCB
K80* (A6P)	Relay on PCB
M1P	Unit Pump

Part n°	Description
M2P	# Domestic hot water pump
M2S	# 2-Way valve for cooling mode
M4S	# Shut off valve - Inlet Leak Stop
M5S	* 3-Way Valve for space heating / DHW
P* (A14P)	* Terminal
P1M	Display
PC (A15P)	* Power circuit
PHC-T (A6P)	Thermal cutout detection
Q*DI	# Earth Leakage Circuit Breaker
Q1L	Thermal protector backup heater
Q2L	Thermal protector booster heater
Q4L	# Safety thermostat
R1H (A2P)	* Humidity sensor
R1T (A1P)	Outlet water heat exchanger thermistor
R1T (A2P)	* Ambient sensor On/OFF thermostat
R1T (A14P)	* Ambient sensor user interface
R2T (A1P)	Outlet backup heater thermistor
R2T (A2P)	* External sensor (floor or ambient)
R5T	Domestic hot water thermistor
R6T	* External in- or outdoor ambient thermistor
S1S	# Preferential kWh rate PS contact
S2S	# Electrical meter pulse input 1
S3S	# Electrical meter pulse input 2
S4S	# Smartgrid feed-in
S10S-S11S	# Low voltage smartgrid contact
ST6 (A30P)	* Connector
TS1	Touch Sensor
X*A, X*Y, X**Y*, X*H, X**H*	Connector
X*M	Terminal strip
Z*C	Noise Filter (Ferrite Core)

4D148696B

# 8 Wiring diagrams

## 8 - 2 Wiring Diagrams - Hydro Module

8

EPBX10A4V / EPBX10A9W  
EPBX14A4V / EPBX14A9W

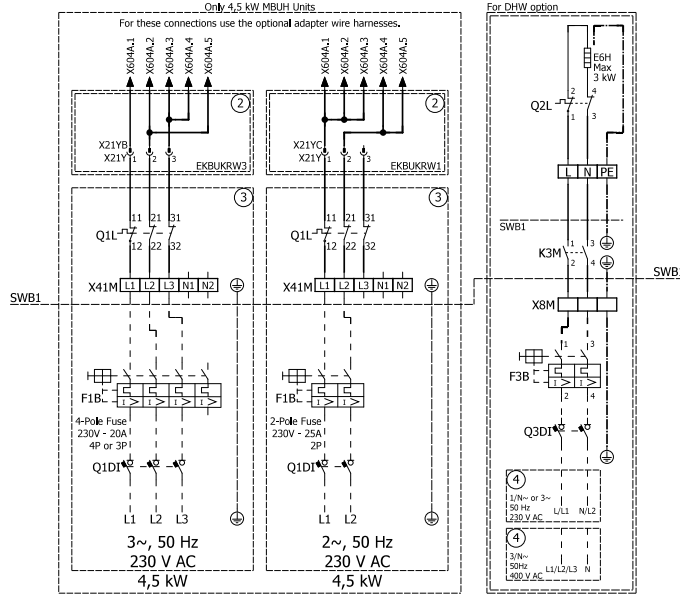

4D148696B

EPBX10A4V / EPBX10A9W  
EPBX14A4V / EPBX14A9W

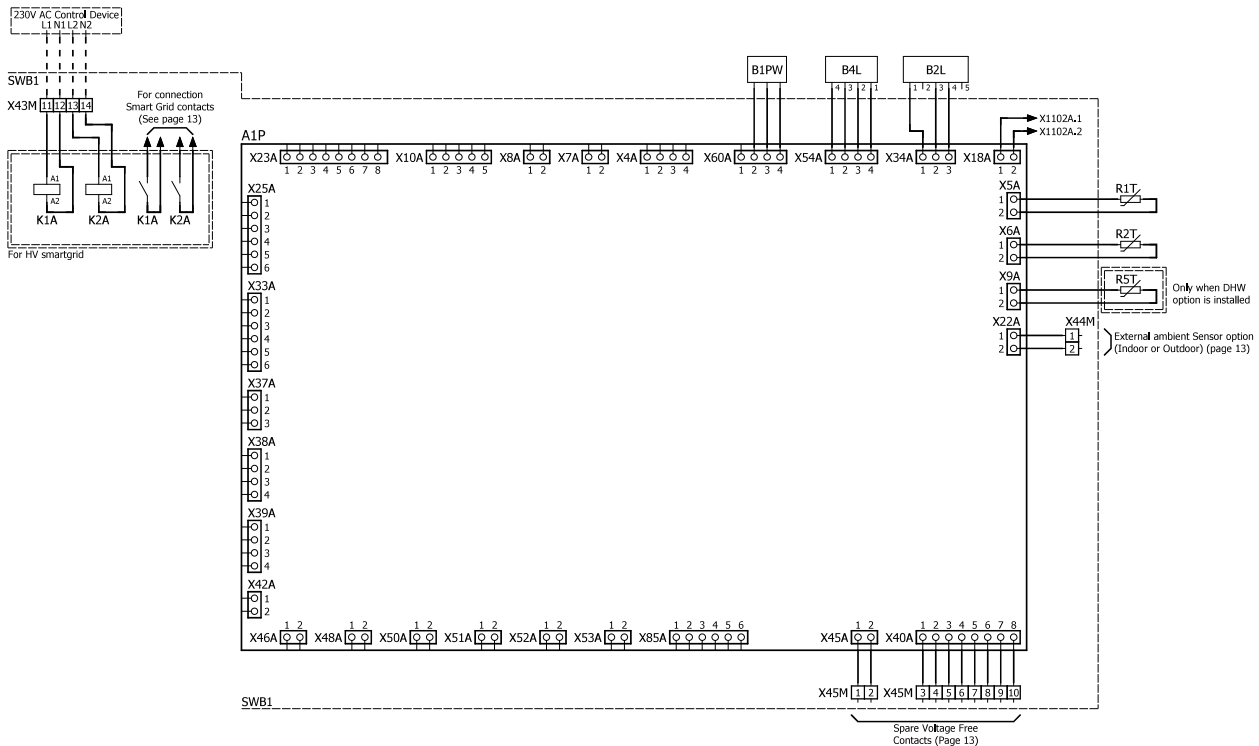

4D148696A

# 8 Wiring diagrams

## 8 - 2 Wiring Diagrams - Hydro Module

### EPBX10A4V / EPBX10A9W EPBX14A4V / EPBX14A9W

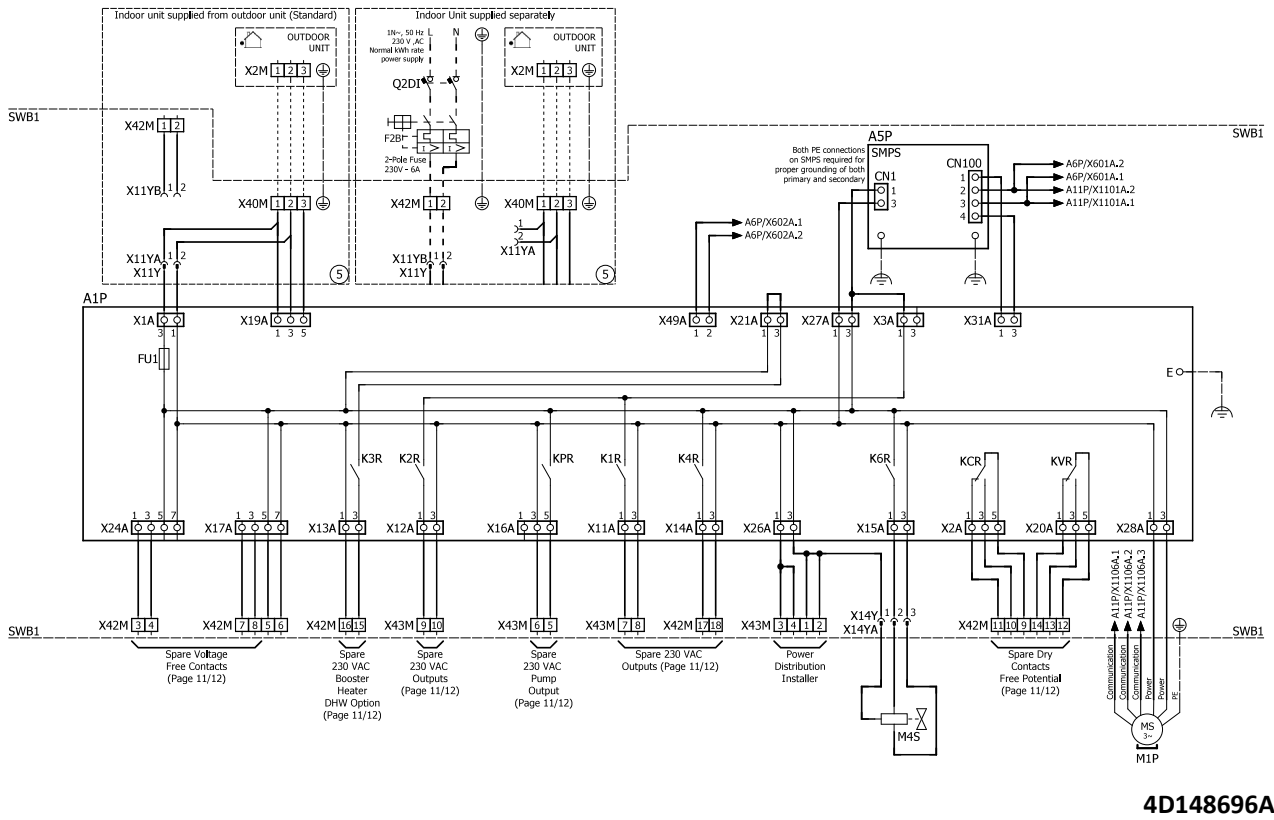

4D148696A

### EPBX10A4V / EPBX10A9W EPBX14A4V / EPBX14A9W

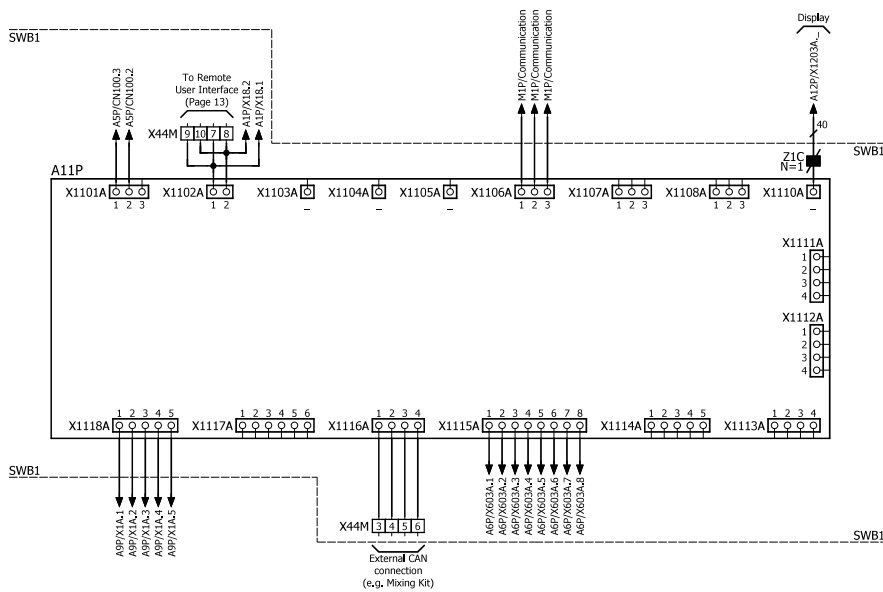

4D148696A

# 8 Wiring diagrams

## 8 - 2 Wiring Diagrams - Hydro Module

8

EPBX10A4V / EPBX10A9W  
EPBX14A4V / EPBX14A9W



4D148696A

EPBX10A4V / EPBX10A9W  
EPBX14A4V / EPBX14A9W

### Connection Possibilities for X42M / X43M (Page 1/2)

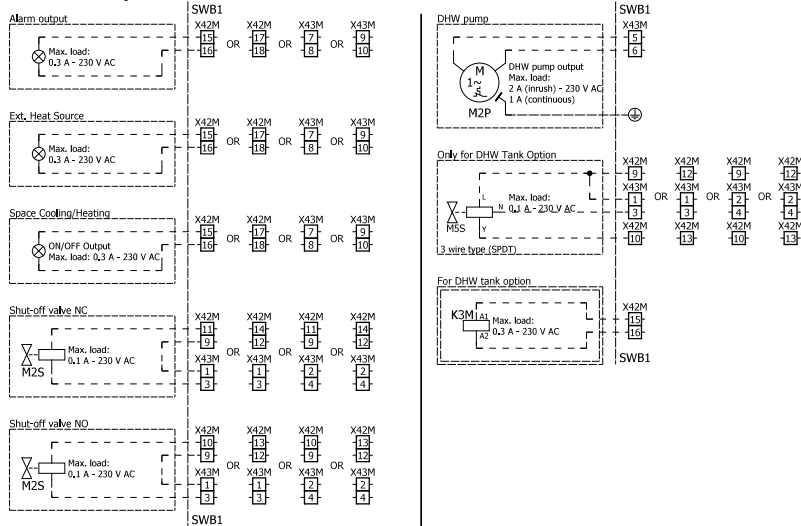

X42M Ports	Description	Max No. of wires per position
1	Alternative Power Supply - L (230 VAC)	1
2	Alternative Power Supply - N (230 VAC)	1
3	Input 1 Room Thermostat 1 (Voltage Free)	1
4	Input 2 Room Thermostat 1 (Voltage Free)	1
5	L Room Thermostat (1 & 2)	2 (See note 3)
6	N Room Thermostat (1 & 2)	2 (See note 3)
7	Input 1 Room Thermostat 2 (Voltage Free)	1
8	Input 2 Room Thermostat 2 (Voltage Free)	1
9	Spare Dry Contact Free Potential 1 - COM	1
10	Spare Dry Contact Free Potential 1 - NO	1
11	Spare Dry Contact Free Potential 1 - NC	1
12	Spare Dry Contact Free Potential 2 - COM	1
13	Spare Dry Contact Free Potential 2 - NO	1
14	Spare Dry Contact Free Potential 2 - NC	1
15	Spare 230 VAC Output 1 (NO)	1
16	Spare 230 VAC Output 1 (N)	1
17	Spare 230 VAC Output 2 (NO)	1
18	Spare 230 VAC Output 2 (N)	1

X43M Ports	Description	Max No. of wires per position
1	Power Distribution Installer - L (230 VAC)	1
2	Power Distribution Installer - L (230 VAC)	1
3	Power Distribution Installer - N (230 VAC)	1
4	Power Distribution Installer - N (230 VAC)	1
5	Spare 230 VAC Output Pump (NO)	1
6	Spare 230 VAC Output Pump (N)	1
7	Spare 230 VAC Output 3 (NO)	1
8	Spare 230 VAC Output 3 (N)	1
9	Spare 230 VAC Output 4 (NO)	1
10	Spare 230 VAC Output 4 (N)	1
11	HV Smart Grid 1 - L (230 VAC)	1
12	HV Smart Grid 1 - N (230 VAC)	1
13	HV Smart Grid 2 - L (230 VAC)	1
14	HV Smart Grid 2 - N (230 VAC)	1

Notes:  
 1. For X42M Ports 3-4 and 7-8: Only ON/OFF voltage free contacts  
 2. Terminal combinations can only be used for one option.  
 3. For terminals X42M/5-6 a twin Ferrule is needed if 2 wires are needed.

4D148696A

# 8 Wiring diagrams

## 8 - 2 Wiring Diagrams - Hydro Module

### EPBX10A4V / EPBX10A9W EPBX14A4V / EPBX14A9W

### Connection Possibilities for X42M / X43M (Page 2/2)

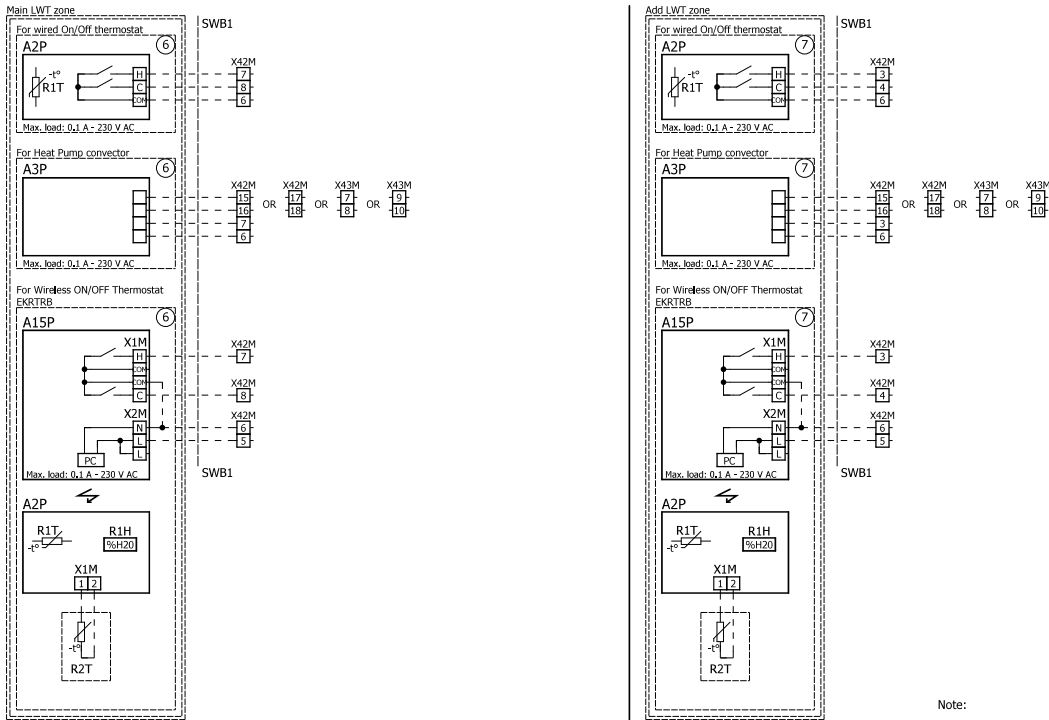

Note:  
Refer to page 10 of the Wiring Diagram for Terminal Block designation legend.

4D148696B

### EPBX10A4V / EPBX10A9W EPBX14A4V / EPBX14A9W

### Possible connections for X44M / X45M

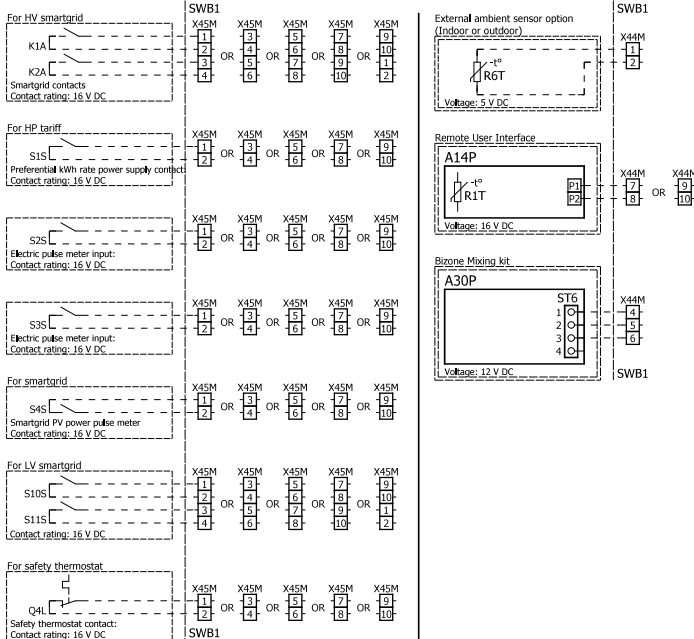

X44M Ports	Description	Max No. of wires per position
1	External Thermistor	1
2	External Thermistor GND	1
3	CAN Bus VCC	1
4	CAN Bus High	1
5	CAN Bus Low	1
6	CAN Bus GND	1
7	P1 - 1	1
8	P2 - 1	1
9	P1 - 2	1
10	P2 - 2	1

X45M Ports	Description	Max No. of wires per position
1	Spare Voltage Free Contact NO 1	1
2	Spare Voltage Free Contact GND 1	1
3	Spare Voltage Free Contact NO 2	1
4	Spare Voltage Free Contact GND 2	1
5	Spare Voltage Free Contact NO 3	1
6	Spare Voltage Free Contact GND 3	1
7	Spare Voltage Free Contact NO 4	1
8	Spare Voltage Free Contact GND 4	1
9	Spare Voltage Free Contact NO 5	1
10	Spare Voltage Free Contact GND 5	1

- Notes:
1. Recommended to use High Grade Contact material
  2. For Ports 1 to 10 of X45M: Only ON/OFF voltage free contacts
  3. Terminal combinations can only be used for one option.

4D148696A

# 8 Wiring diagrams

## 8 - 3 Power Supply, Back-up Heater

8

EPBX10A4V / EPBX10A9W  
EPBX14A4V / EPBX14A9W

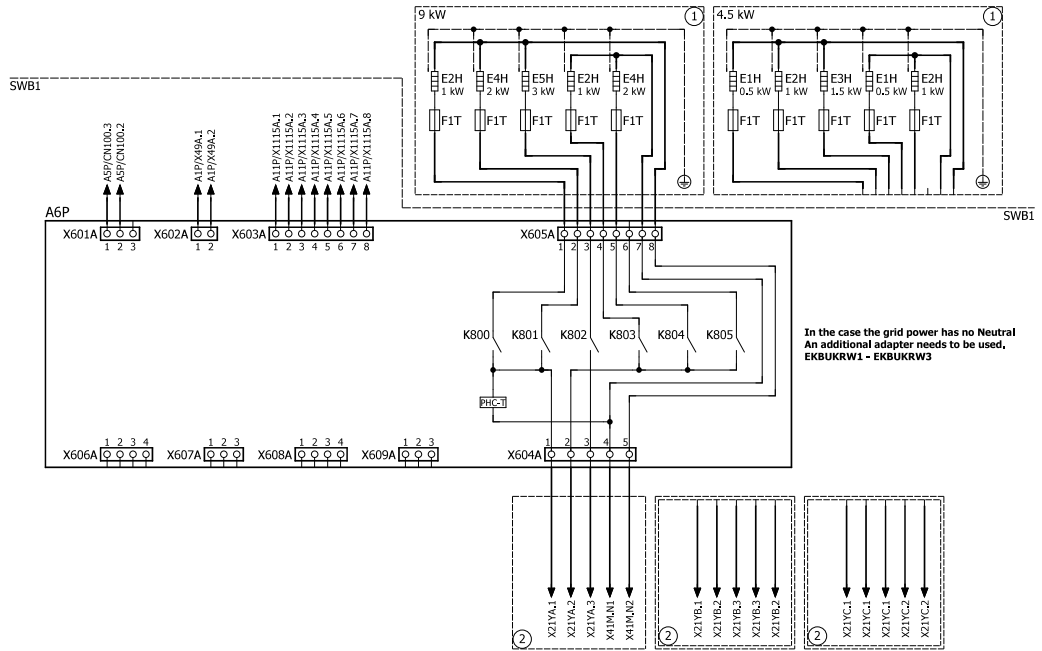

4D148696A

EPBX10A4V / EPBX10A9W  
EPBX14A4V / EPBX14A9W

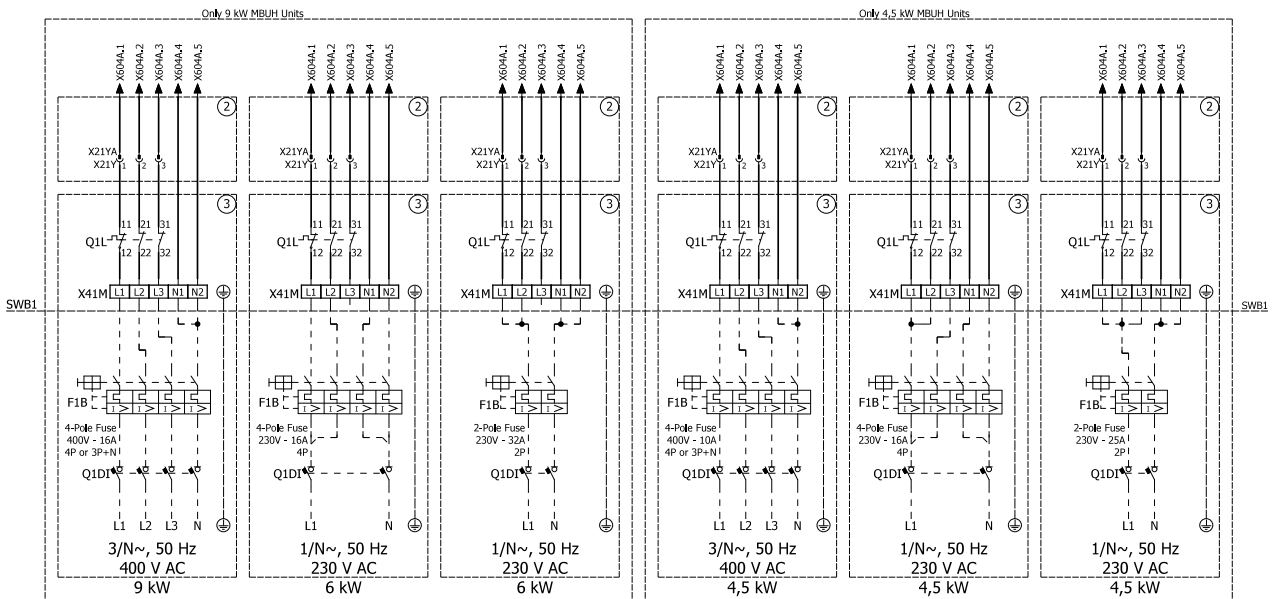

4D148696B

# 9 External connection diagrams

## 9 - 1 External Connection Diagrams

EPBX10A4V  
 EPBX10A9W  
 EPBX14A4V  
 EPBX14A9W

Electrical connection diagram Altherma 4 Wall Mounted For more details please check unit wiring

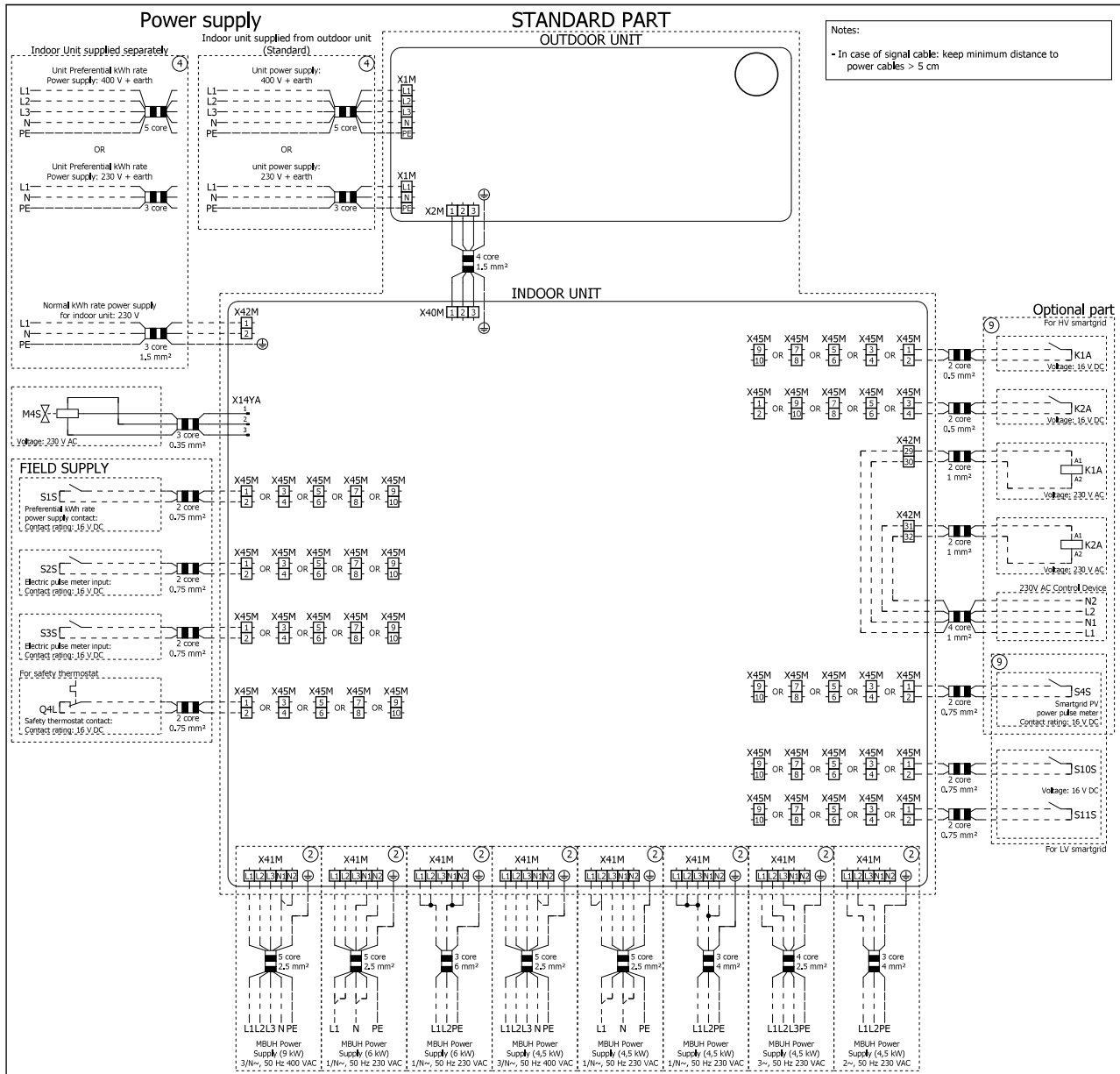

4D152877B



# 10 Installation

## 10 - 1 Installation Method

EPBX10A4V  
EPBX10A9W  
EPBX14A4V  
EPBX14A9W

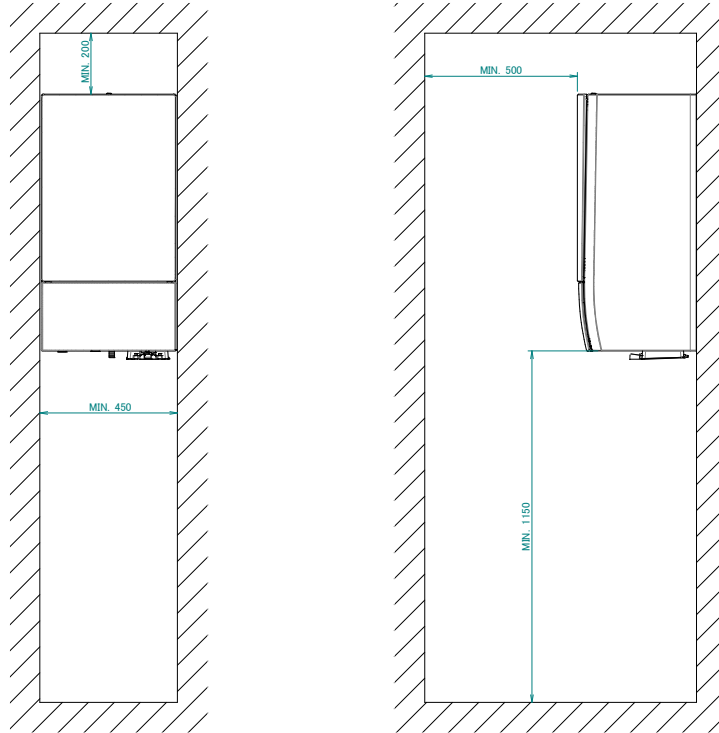

3D154623

# 11 Hydraulic performance

## 11 - 1 Static Pressure Drop Unit

11

EPBX10A4V

EPBX10A9W

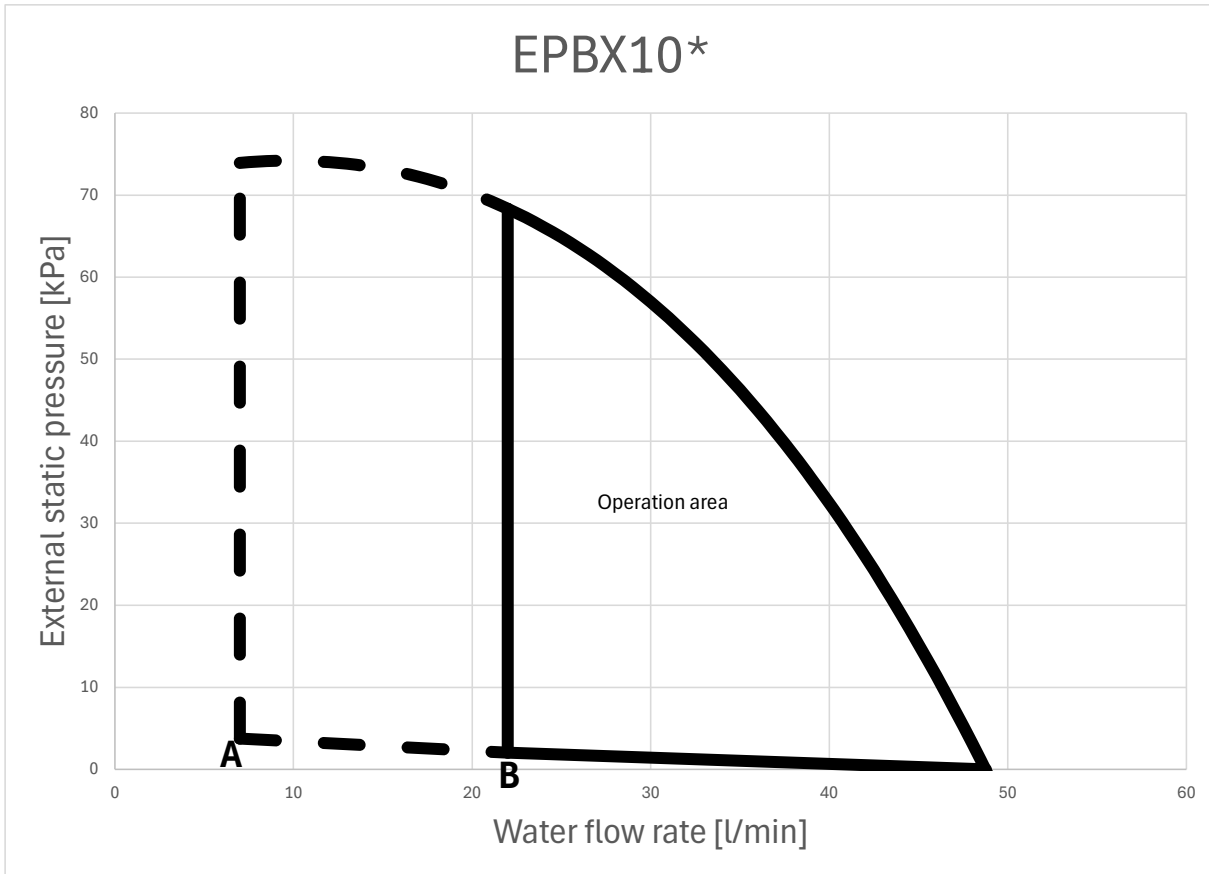

A Minimum water flow rate during normal operation

B Minimum water flow rate during defrost/backup heater operation

Operation area is extended to lower flow rates only in case the unit operates with heat pump only.

See dashed lines

Notes

1. Selecting a flow outside the operating area can damage the unit or cause the unit to malfunction. See also the minimum and maximum allowed water flow range in the technical specifications.
2. Make sure water quality complies with EU Directive ·2020/2184·
3. Unit "External static pressure" includes the shut-off valve

4D154617

# 11 Hydraulic performance

## 11 - 1 Static Pressure Drop Unit

EPBX14A4V

EPBX14A9W

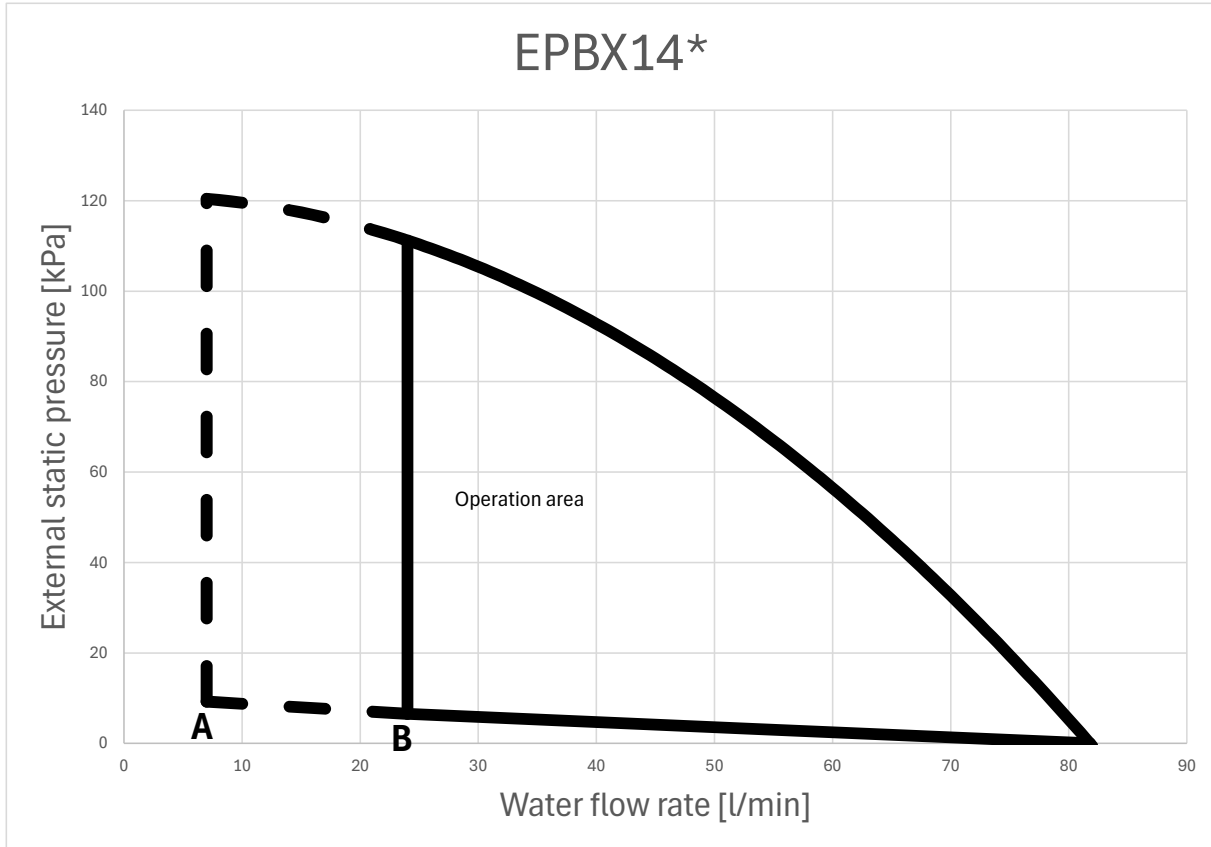

- A Minimum water flow rate during normal operation
- B Minimum water flow rate during defrost/backup heater operation

Operation area is extended to lower flow rates only in case the unit operates with heat pump only.  
See dashed lines

Notes

1. Selecting a flow outside the operating area can damage the unit or cause the unit to malfunction. See also the minimum and maximum allowed water flow range in the technical specifications.
2. Make sure water quality complies with EU Directive ·2020/2184·
3. Unit "External static pressure" includes the shut-off valve

4D154679

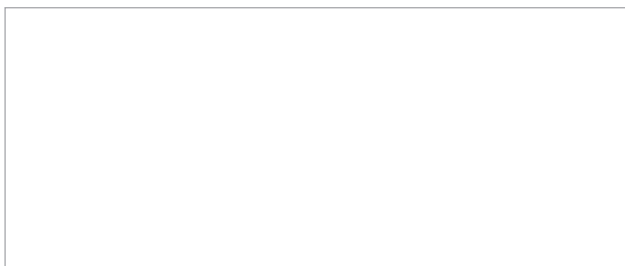

EEDEN25

03/2025



The present leaflet is drawn up by way of information only and does not constitute an offer binding upon Daikin Europe N.V. Daikin Europe N.V. has compiled the content of this leaflet to the best of its knowledge. No express or implied warranty is given for the completeness, accuracy, reliability or fitness for particular purpose of its content and the products and services presented therein. Specifications are subject to change without prior notice. Daikin Europe N.V. explicitly rejects any liability for any direct or indirect damage, in the broadest sense, arising from or related to the use and/or interpretation of this leaflet. All content is copyrighted by Daikin Europe N.V.